

SPARK EH

100-360 Ton



202403

Chen Hsong

Unit 2001, 20th Floor, Citicorp Centre, 18 Whitfield Road, Hong Kong

marketing@chenhsong.com

+ 852-2665-3222

www.chenhsong.com

www.chenhsong.com

The New EH Series – A Spark Family Member
Top Scores on All Aspects of All-Electric Performance



Applicability



Power



Control



Precision



Savings

The Next Generation of All-Electrics,
 Available Today.

Electric x Hydraulic

Reap the benefits of both electric and hydraulic drive trains for additional applicability without sacrificing precision and performance.

Software x Hardware

Highly-optimised control algorithms work together with fine-tuned hardware designs to deliver perfect motion control.

Speed x Precision

Stability and repeatability at high speed for even the most demanding applications.

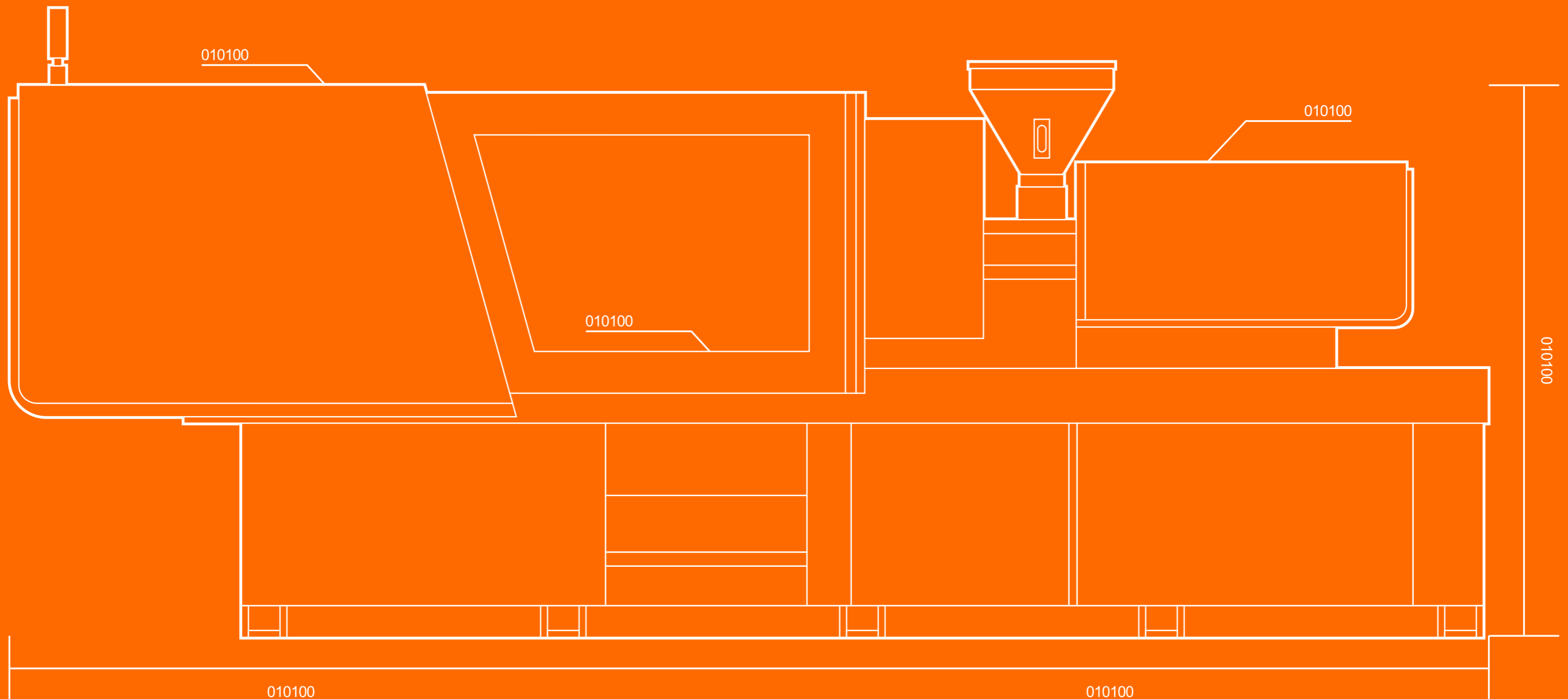

Applicability

All-Adapt

One machine to make them all – from ultra-thin parts requiring ultra-fast speed and responses, to ultra-thick parts demanding rock-solid stability under low-speed and prolonged high-pressure conditions.

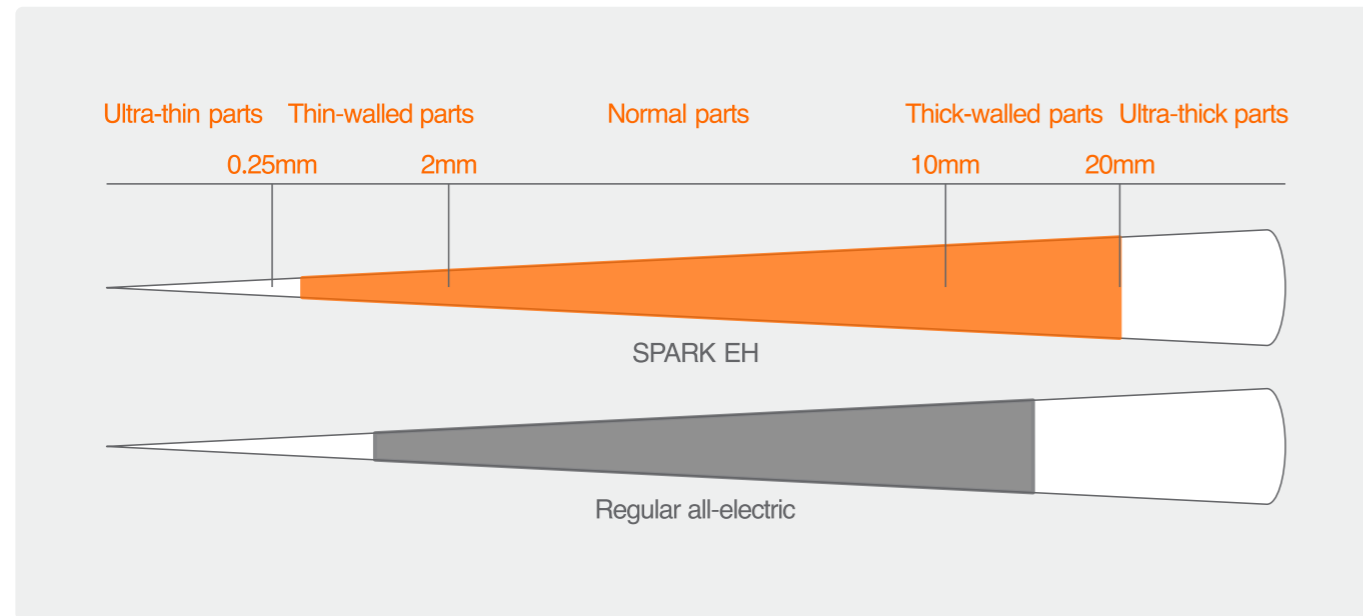

From ultra-thick optical parts to ultra-thin packaging, the SPARK EH does them all.

Euromap-style Ejector Support

Wide applicability for different moulds



Integrated Hydraulic Core Pulls

SPARK EH100 to SPARK EH300

One set of hydraulic cores pull standard



Savings

Redefining Energy Efficiency



SPARK EH is **12%** more power efficient (and thus less cost to run) than regular competition offerings for the same productivity.

Green manufacturing

Patented platen design combined with low-noise servosystem and advanced control algorithms ensure silky-smooth motion.

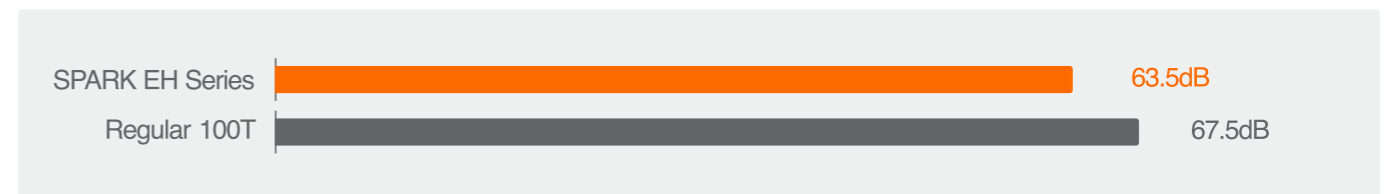

SPARK EH is **5.9%** quieter, and thus greener, than competition offerings.

Top-of-the-line lubrication

Centralised automatic lubrication system
LUBE (Japan)



Adaptive control system

ASRS-Auto Stress Release System

“ASRS” is a revolutionary technology that, again, employs high-speed computer algorithms that dynamically monitors, via high-speed digital pressure transducers, the actual motion of the injection screw (<1ms scan time).

The computer controller makes real-time adjustments to the motion of the screw when detecting motions that may lead to accumulation of internal stresses on the part — typically the No.1 enemy of high yields and the No.1 reason for rejects.

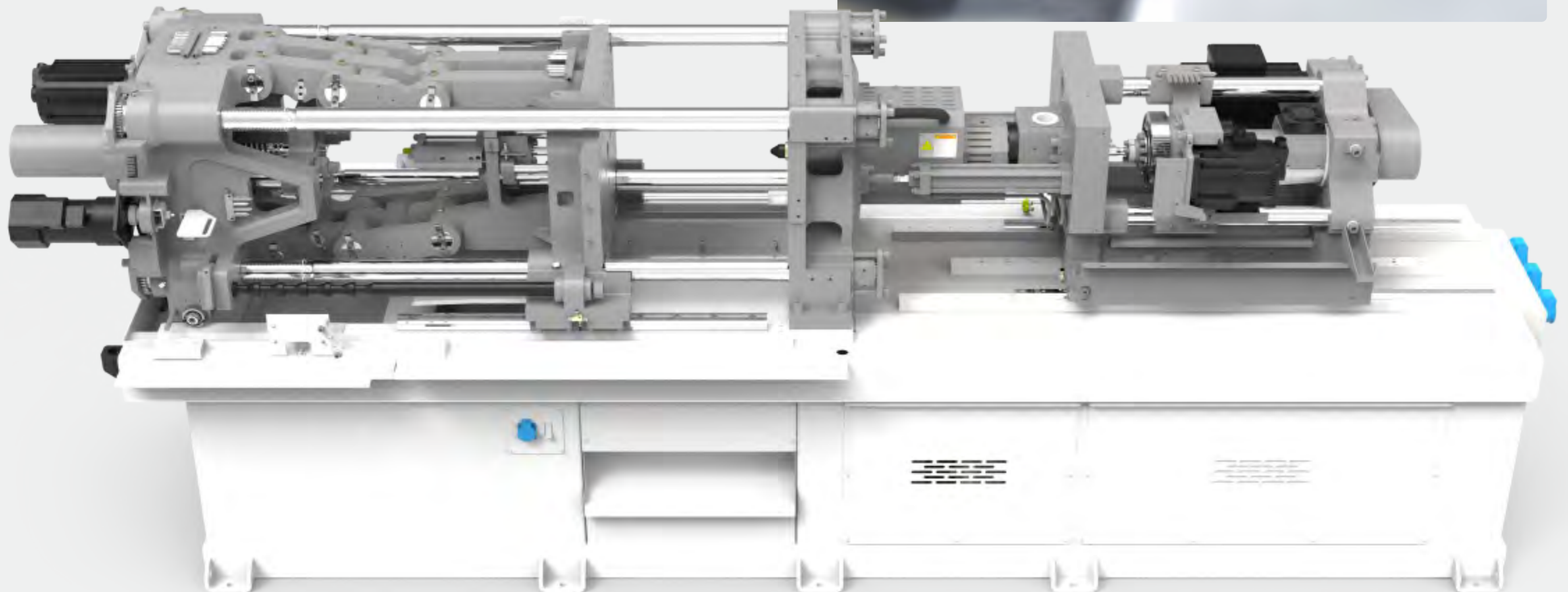

Efficient Control

ABC-Agile Boost Control

Marriage of a proprietary ultra-high-response servo system with very-high-speed advanced computer control, yielding no-compromise levels of responsiveness — from zero to 2000 rpm in less than 30 ms! That is ten times faster than traditional all-electric machines (300 ms) in the China market!

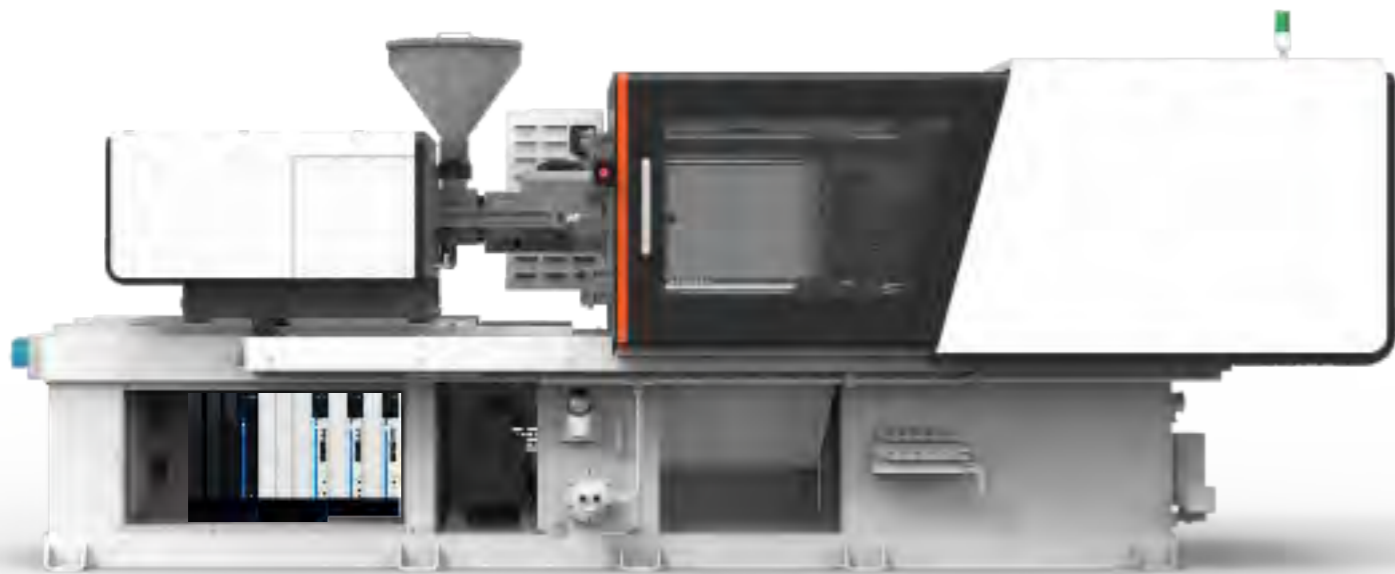

High-end Advanced Computer Controller

15" touch-screen, easy-to-use HMI with user-friendly UI — power at your fingertips.

01 High speed CPU for real-time calculations

Software dynamically adjusts and compensates all hardware motion during injection, holding, recovery, ejection and clamping.

02 Ultra-fast responses

High-end CPU enables lightning speed closed-loop calculations for ultra-fast dynamic responses, superior precision and perfect repeatability.



35% Faster Dry Cycle 10% More Speed

Model	Clamp Open (s)	Clamp Close (s)	Total Clamping (s)	Opening Stroke (mm)
SPARK EH Series	0.86	0.98	1.84	322
Competition	1.34	1.52	2.86	294

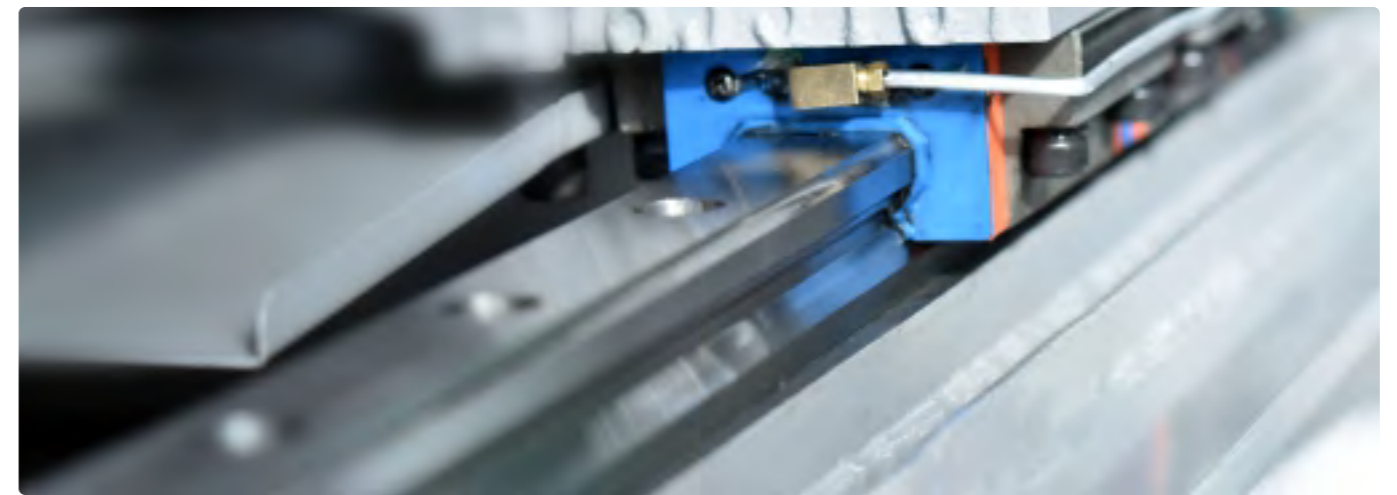

Low friction and High precision

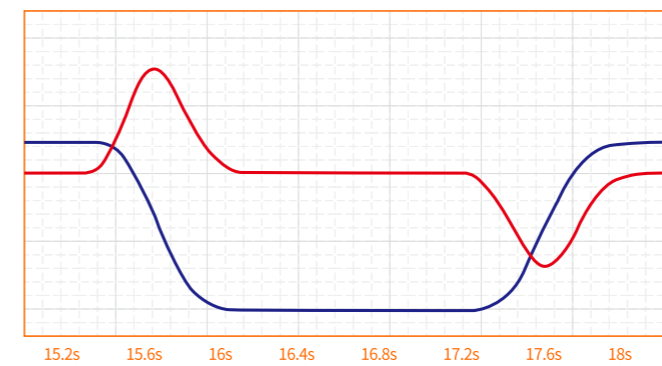

SPARK EH Series

High-end linear guide rails for moving platen

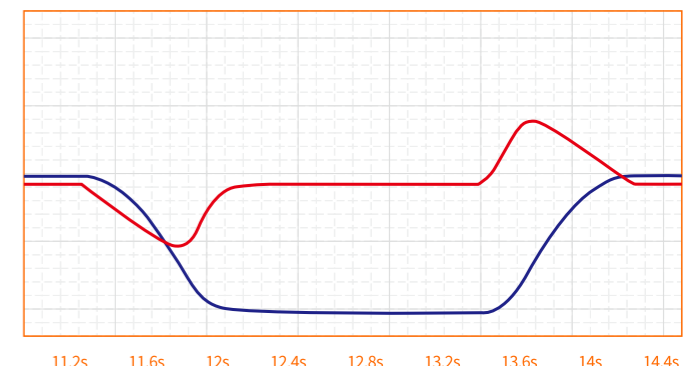

Competition

No linear guide rails

Holding Pressure Comparison

Rock-solid stability under low-speed and prolonged high-pressure conditions

Model	Holding Pressure (Mpa)	Holding Time
SPARK EH Series	180(+2%)	>300*(>7x)
Competition	176	43.8

*Subject to different product applications and cycle times



Precision

AxP with Floating Point Toggle

“AxP” (Algorithm Cross-Protection) is based on high-end electronics, fine-tuned mechanical design and high-speed computer algorithms. It provides total protection to the mould during high-speed clamp closing by monitoring and adjusting, in real-time, the dynamical motions of the clamping ball-screw. The “Floating Point Toggle” design, on the other hand, adds back to the rigid ball-screw system a soft “buffer” that is inherent in a hydraulic system, eliminating mechanical shocks and vibrations and, thereby, reducing operating noise and ensuring buttery-smooth mechanical motions. Both technologies work hand-in-hand together to provide world-class protection to the mould and the machine mechanisms, smooth operations, as well as long and extended machine life.

High Precision and High Performance

Patented Circular Platen design ensures even stress distribution and low deformations for higher quality parts and superior dimensional stability

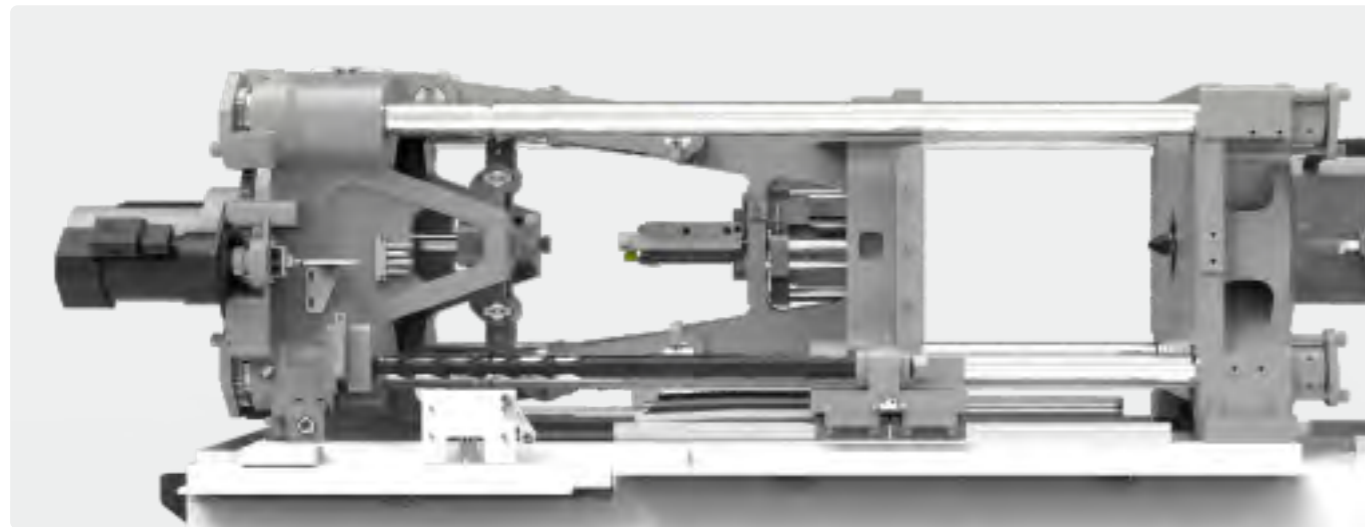

Comparison between major brands on platen deformation under similar clamping conditions.

Unique Patented Circular Platen Design, High Rigidity and Lowest Deformation

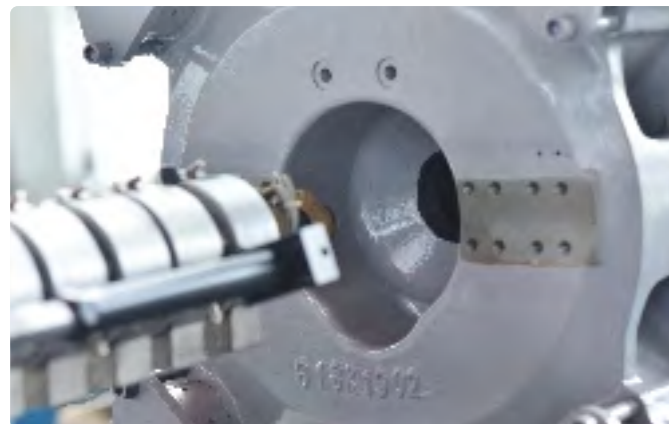

High-strength Machine Base Designed In Japan

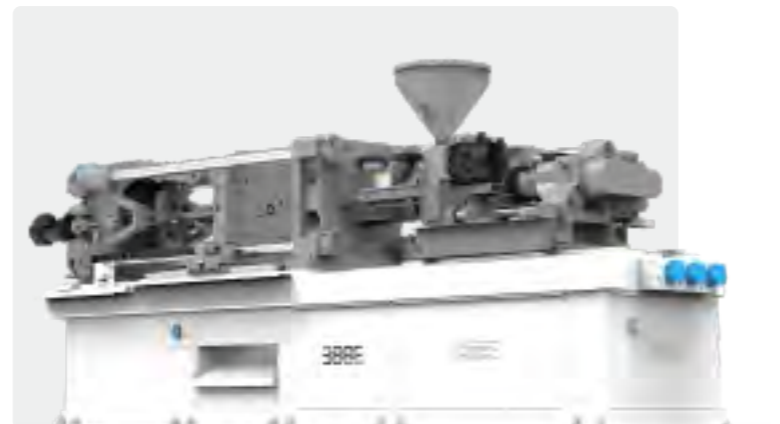

Tail Platen Adjustment Mechanism

Low friction, high stability

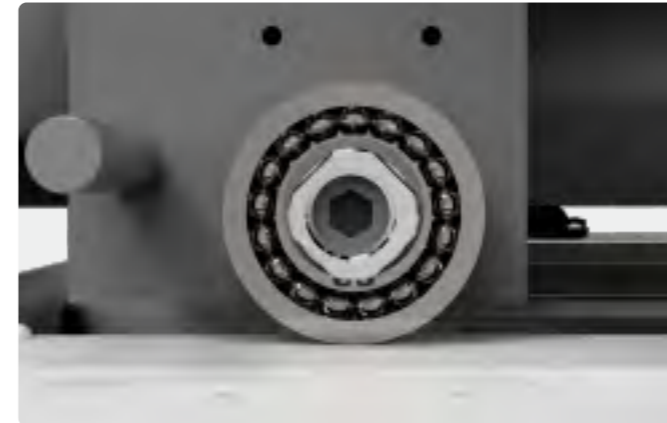

SPARK EH Series



Competition

Digital Temperature Control

Advanced PID control algorithms ensure high-precision barrel temperature control with superior disturbance resistance.



Specialty-developed IPM Servomotor

With fast response, large torque, low noise and mild temperature profile, 23-bit High-Precision Encoder ensures ultra-high positional accuracy.



Rapid-response Pressure Transducer

Name-brand high-precision pressure transducers ensure the finest performance and protection levels.



Standard Features

Clamping Unit			
1 Ejector-on-fly	2 Plasticising-on-fly	3 Magnetic safeties for guard doors	4 Centralised automatic lubrication system
5 In-mould ejection	6 Two-stage ejection	7 Euromap-style ejector support	8 Linear guide rails for clamping units
9 2 sets of air blows control	10 1 set of hydraulic core pull		
Injection Unit			
1 Two-stage injection	2 Low-pressure injection	3 Compressive moulding	4 High-efficiency ceramic heater bands
5 Chrome plated screw	6 Close loop temperature control at barrel inlet	7 Linear guide rails for injection units	
Controller			
1 Tri-color status indicator	2 15" touch-screen panel	3 "One-touch" servo dynamic profile setting	
4 SSR for barrel heating	5 Robot interface (non-Euromap)	6 Metric/imperial units	
7 STO-compliant fast-dynamic-response servosystem			

Optional Features

Clamping Unit			
1 Air blows	2 Customised platen layout		
Injection Unit			
1 Screws and nozzles for specialised applications	2 High-pressure tight-seal nozzle flange	3 Sprayed hopper	
Hydraulics			
1 Connection for magnetic/hydraulic tool fastening system	2 Core pulls (hydraulic, pneumatic and/or electric)		
Controller			
1 Connection for gas-assist	2 Euromap 18 robot interface	3 Euromap 12 robot interface	4 Euromap 67 robot interface
5 Broken heating wire detection	6 Connection for microfoaming	7 Closed-loop clamping force control	
8 Power-efficient barrel heating alternatives			

SPARK EH100

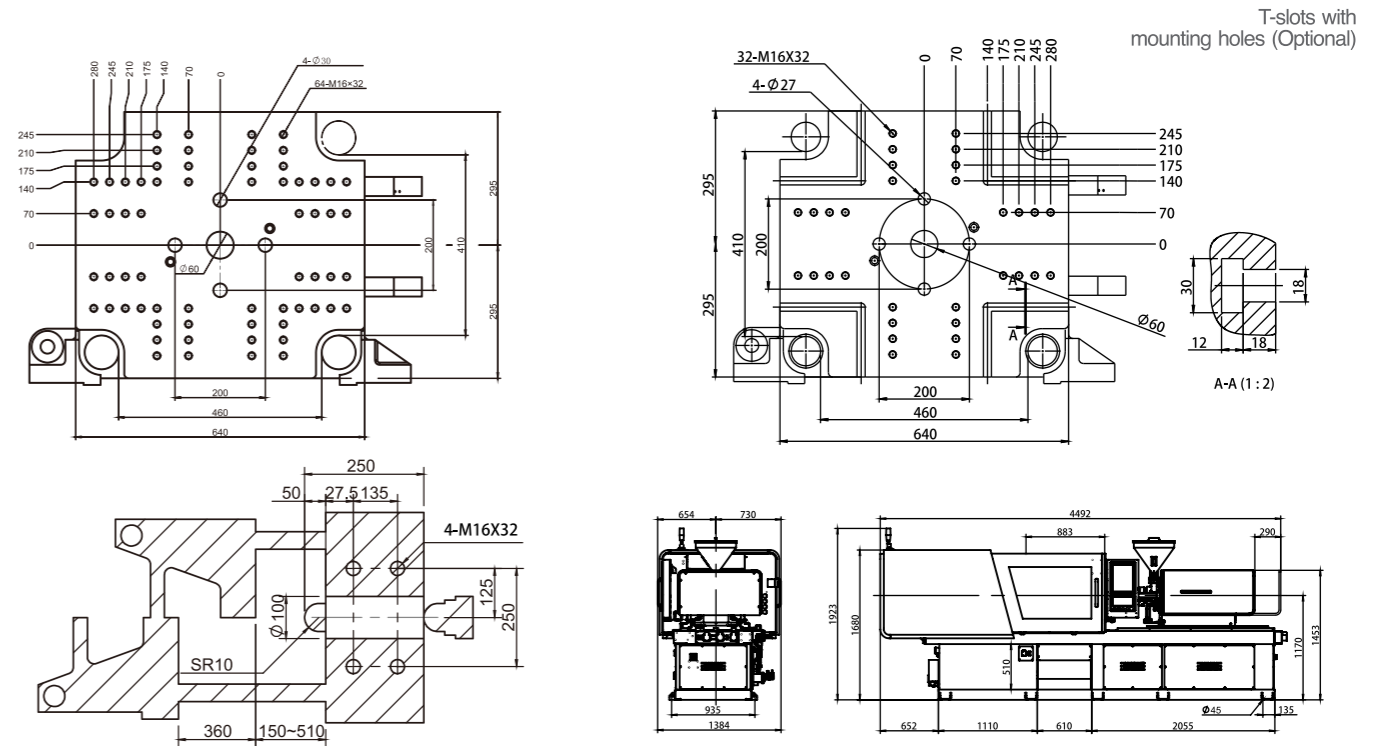

INJECTION UNIT	A	B	C	CLAMPING UNIT		
Screw Diameter	mm	25	28	32	Clamping Force	kN 1000
Screw Stroke	mm	100	112	112	Opening Force	mm 360
Swept Volume	cm ³	49	69	90	Min. Mould Thickness	mm 150
Shot Weight (PS)	g	45	63	82	Max. Mould Thickness	mm 510
Shot Weight (PS)	oz	1.6	2.2	2.9	Space Between Tie Bars (HxV)	mm 460x410
Injection Rate	cm ³ /s	98	123	161	Max. Daylight	mm 870
Injection Speed	mm/s		200		Ejector Force	kN 34
Injection Pressure	MPa	260	220	175	Ejector Stroke	mm 100
Holding Pressure	MPa	208	176	140		
Plasticising Capacity	g/s	7.8	11	15	POWER PACK	
Screw Rotation Speed (max.)	rpm		350		Input Power	380V 50Hz
Barrel Heating Power	kW	6.3	7.2	8.2	Max. Power Draw	kVA 42
Barrel Temperature Zones			3+1		Max. System Pressure	MPa 17.5
Nozzle Contact Force	kN		41		System Flow	L/min 30
					Oil Tank Capacity	L 60
OTHERS						
Machine Dimensions (LxWxH)	mm	4560x1384x1923				
Machine Weights	t	3.9				

The company keeps upgrading the products and reserves the right to change the product specifications and parameters without prior notice. The final interpretation to the above specifications and parameters belongs to the company.

SPARK EH120

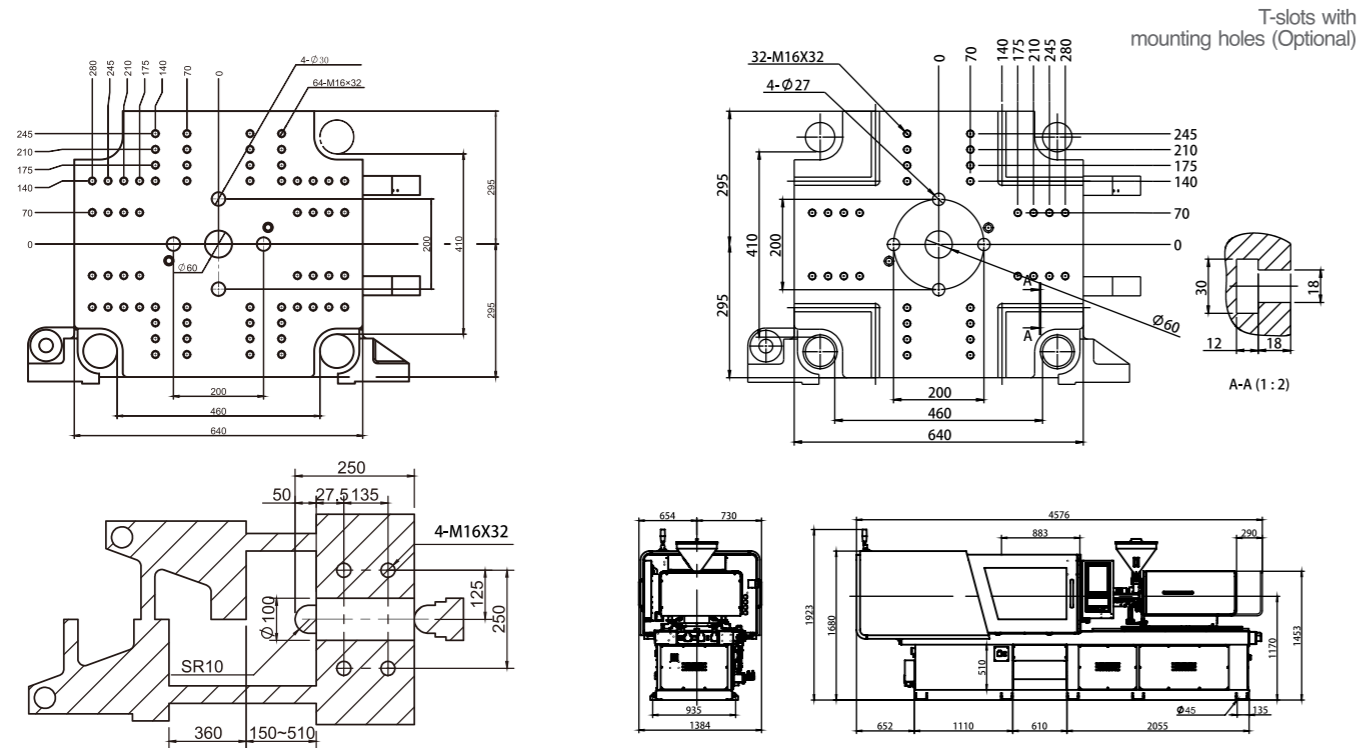

INJECTION UNIT	A	B	C	CLAMPING UNIT			
Screw Diameter	mm	28	32	36	Clamping Force	kN	1200
Screw Stroke	mm	112	112	112	Opening Force	mm	360
Swept Volume	cm ³	69	90	114	Min. Mould Thickness	mm	150
Shot Weight (PS)	g	63	82	103	Max. Mould Thickness	mm	510
Shot Weight (PS)	oz	2.2	2.9	3.6	Space Between Tie Bars (HxV)	mm	460x410
Injection Rate	cm ³ /s	123	161	204	Max. Daylight	mm	870
Injection Speed	mm/s		200		Ejector Force	kN	34
Injection Pressure	MPa	220	175	138	Ejector Stroke	mm	100
Holding Pressure	MPa	176	140	110			
Plasticising Capacity	g/s	11	15	21	POWER PACK		
Screw Rotation Speed (max.)	rpm		350		Input Power		380V 50Hz
Barrel Heating Power	kW	7.2	8.2	8.9	Max. Power Draw	kVA	42
Barrel Temperature Zones			3+1		Max. System Pressure	MPa	17.5
Nozzle Contact Force	kN		41		System Flow	L/min	30
					Oil Tank Capacity	L	60

OTHERS

Machine Dimensions (LxWxH) mm 4680x1384x1923

Machine Weights t 4.1

The company keeps upgrading the products and reserves the right to change the product specifications and parameters without prior notice. The final interpretation to the above specifications and parameters belongs to the company.

SPARK EH150

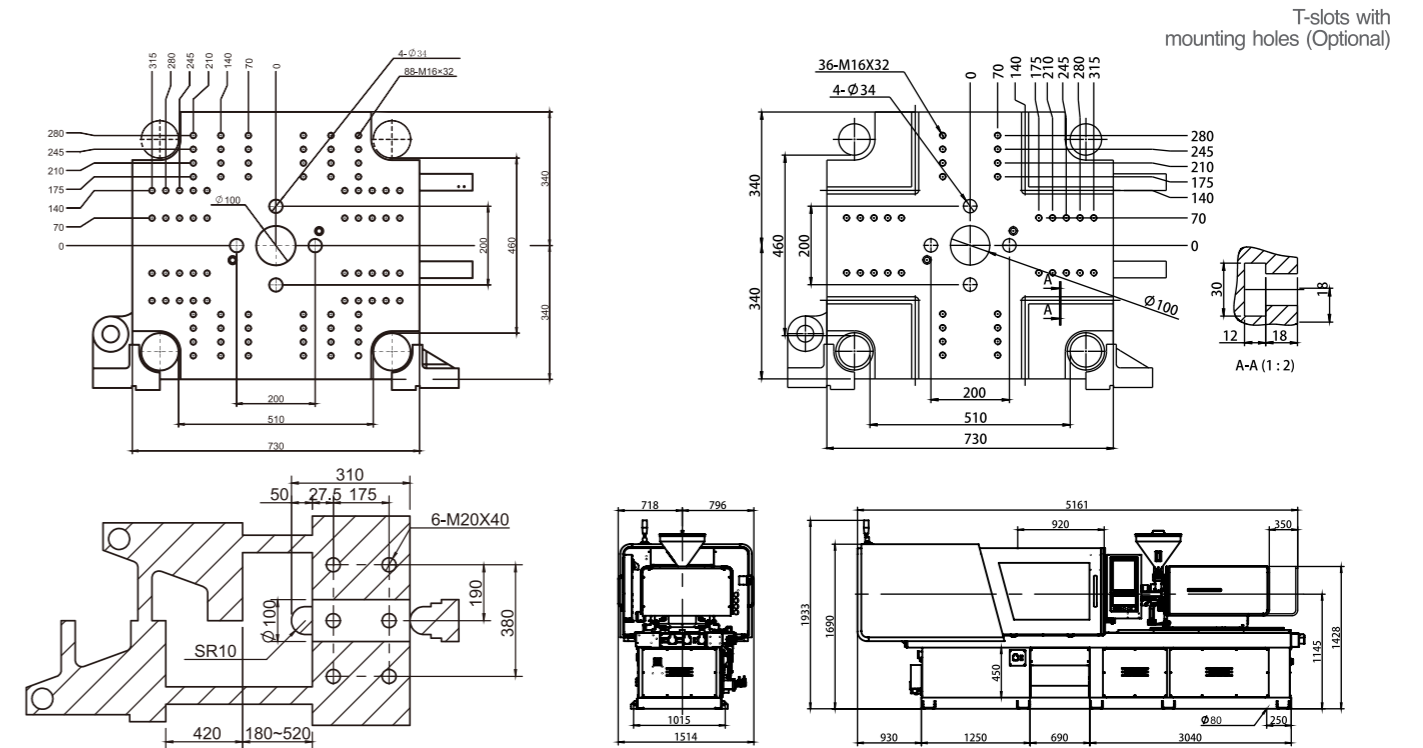

INJECTION UNIT	Standard			EX (Larger Injection Unit)				CLAMPING UNIT			
	A	B	C	A	B	C	D				
Screw Diameter	mm	28	32	36	32	36	41	46	Clamping Force	kN	1500
Screw Stroke	mm	112	112	112	160	180	205	230	Opening Force	mm	420
Swept Volume	cm ³	69	90	114	128	183	271	382	Min. Mould Thickness	mm	180
Shot Weight (PS)	g	63	82	103	117	167	246	348	Max. Mould Thickness	mm	520
Shot Weight (PS)	oz	2.2	2.9	3.6	4.1	5.9	8.7	12.3	Space Between Tie Bars (HxV)	mm	510x460
Injection Rate	cm ³ /s	123	161	204	160	203	264	332	Max. Daylight	mm	940
Injection Speed	mm/s		200			200			Ejector Force	kN	34
Injection Pressure	MPa	220	175	138	300	235	183	145	Ejector Stroke	mm	120
Holding Pressure	MPa	176	140	110	240	188	146.4	116			
Plasticising Capacity	g/s	11	15	21	15	21	26	35	POWER PACK		
Screw Rotation Speed (max.)	rpm		350			350			Input Power		380V 50Hz
Barrel Heating Power	kW	7.2	8.2	8.9	10.5	12.4	14.3	16.2	Max. Power Draw	kVA	45
Barrel Temperature Zones			3+1			3+1			Max. System Pressure	MPa	17.5
Nozzle Contact Force	kN		61			61			System Flow	L/min	45
									Oil Tank Capacity	L	90

OTHERS

Machine Dimensions (LxWxH) mm 5920x1519x1928

Machine Weights t 5.8 6.5

The company keeps upgrading the products and reserves the right to change the product specifications and parameters without prior notice. The final interpretation to the above specifications and parameters belongs to the company.

SPARK EH180

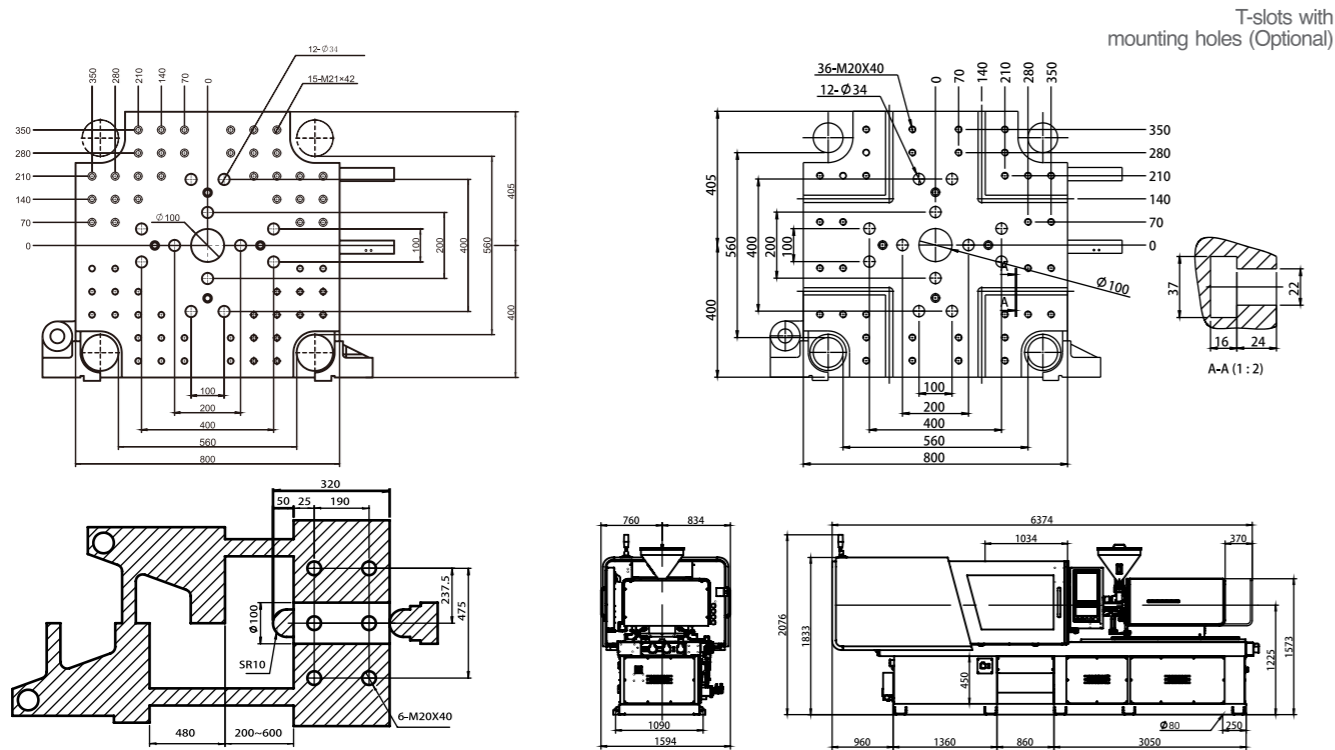

INJECTION UNIT	A	B	C	CLAMPING UNIT		
Screw Diameter	mm	36	41	46	Clamping Force	kN 1800
Screw Stroke	mm	180	205	230	Opening Force	mm 480
Swept Volume	cm ³	183	271	382	Min. Mould Thickness	mm 200
Shot Weight (PS)	g	167	246	348	Max. Mould Thickness	mm 600
Shot Weight (PS)	oz	5.9	8.7	12.3	Space Between Tie Bars (HxV)	mm 560x560
Injection Rate	cm ³ /s	203	264	332	Max. Daylight	mm 1080
Injection Speed	mm/s		200		Ejector Force	kN 67
Injection Pressure	MPa	250	235	177	Ejector Stroke	mm 120
Holding Pressure	MPa	200	188	142		
Plasticising Capacity	g/s	21	26	35	POWER PACK	
Screw Rotation Speed (max.)	rpm		350		Input Power	380V 50Hz
Barrel Heating Power	kW	12.4	14.3	16.2	Max. Power Draw	kVA 50
Barrel Temperature Zones			3+1		Max. System Pressure	MPa 17.5
Nozzle Contact Force	kN		61		System Flow	L/min 74
					Oil Tank Capacity	L 122
OTHERS						
Machine Dimensions (LxWxH)	mm	6530x1564x2074				
Machine Weights	t	7.7				

The company keeps upgrading the products and reserves the right to change the product specifications and parameters without prior notice. The final interpretation to the above specifications and parameters belongs to the company.

SPARK EH230

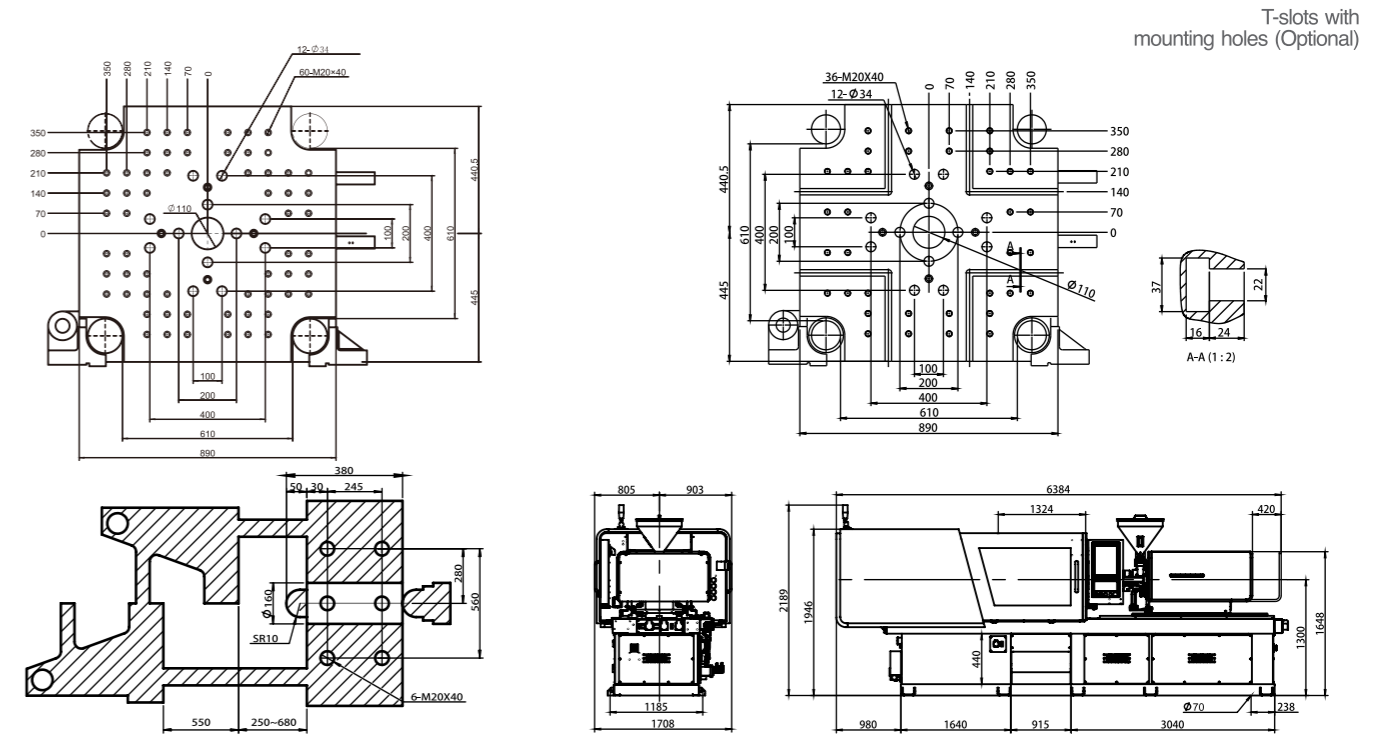

INJECTION UNIT	A	B	C	CLAMPING UNIT		
Screw Diameter	mm	36	41	46	Clamping Force	kN 2300
Screw Stroke	mm	180	205	230	Opening Force	mm 550
Swept Volume	cm ³	183	271	382	Min. Mould Thickness	mm 250
Shot Weight (PS)	g	167	246	348	Max. Mould Thickness	mm 680
Shot Weight (PS)	oz	5.9	8.7	12.3	Space Between Tie Bars (HxV)	mm 610x610
Injection Rate	cm ³ /s	203	264	332	Max. Daylight	mm 1230
Injection Speed	mm/s		200		Ejector Force	kN 67
Injection Pressure	MPa	250	235	177	Ejector Stroke	mm 150
Holding Pressure	MPa	200	188	142		
Plasticising Capacity	g/s	21	26	35	POWER PACK	
Screw Rotation Speed (max.)	rpm		350		Input Power	380V 50Hz
Barrel Heating Power	kW	12.4	14.3	16.2	Max. Power Draw	kVA 74
Barrel Temperature Zones			3+1		Max. System Pressure	MPa 17.5
Nozzle Contact Force	kN		61		System Flow	L/min 74
					Oil Tank Capacity	L 122
OTHERS						
Machine Dimensions (LxWxH)	mm	6785x1676x2185				
Machine Weights	t	10.2				

The company keeps upgrading the products and reserves the right to change the product specifications and parameters without prior notice. The final interpretation to the above specifications and parameters belongs to the company.

SPARK EH300

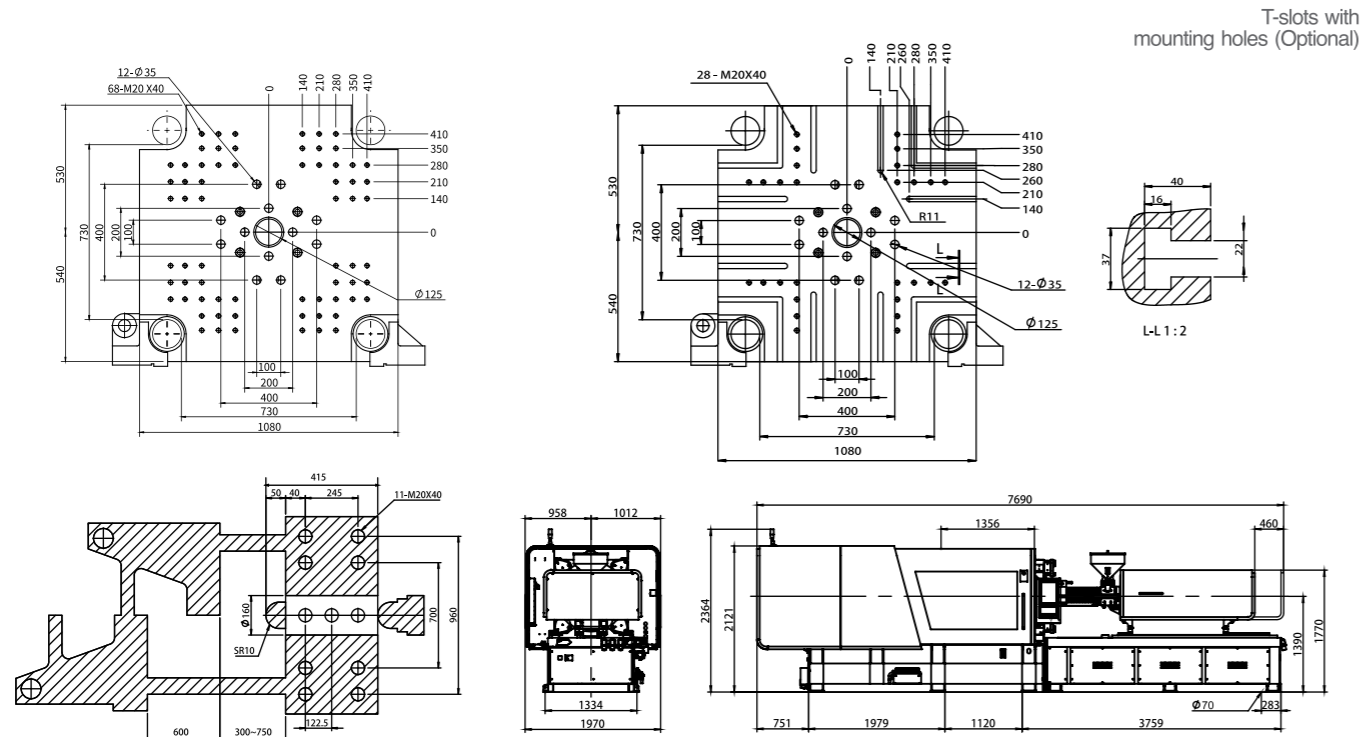

		Standard			EX (Larger Injection Unit)					
INJECTION UNIT		A	B	C	A	B	C	CLAMPING UNIT		
Screw Diameter	mm	46	52	60	60	67	75	Clamping Force	kN	3000
Screw Stroke	mm	230	260	285	300	330	360	Opening Force	mm	600
Swept Volume	cm ³	382	552	805	848	1163	1590	Min. Mould Thickness	mm	300
Shot Weight (PS)	g	351	507	740	780	1070	1462	Max. Mould Thickness	mm	750
Shot Weight (PS)	oz	12.4	17.9	26	27.6	37.8	51.6	Space Between Tie Bars (HxV)	mm	730x730
Injection Rate	cm ³ /s	332	425	565	565	705	883	Max. Daylight	mm	1350
Injection Speed	mm/s		200			200		Ejector Force	kN	67
Injection Pressure	MPa	306	240	180	234	188	150	Ejector Stroke	mm	160
Holding Pressure	MPa	244	192	144	187	150	120			
Plasticising Capacity	g/s	30	48	64	50	80	95	POWER PACK		
Screw Rotation Speed (max.)	rpm		300			235		Input Power		380V 50Hz
Barrel Heating Power	kW	16.2	22.8	29.4	29.4	36	42.6	Max. Power Draw	kVA	100
Barrel Temperature Zones					4+1			Max. System Pressure	MPa	17.5
Nozzle Contact Force	kN				90			System Flow	L/min	90
								Oil Tank Capacity	L	135
OTHERS										
Machine Dimensions (LxWxH)	mm	7700x1970x2365								
Machine Weights	t	14.9								

The company keeps upgrading the products and reserves the right to change the product specifications and parameters without prior notice. The final interpretation to the above specifications and parameters belongs to the company.

SPARK EH360

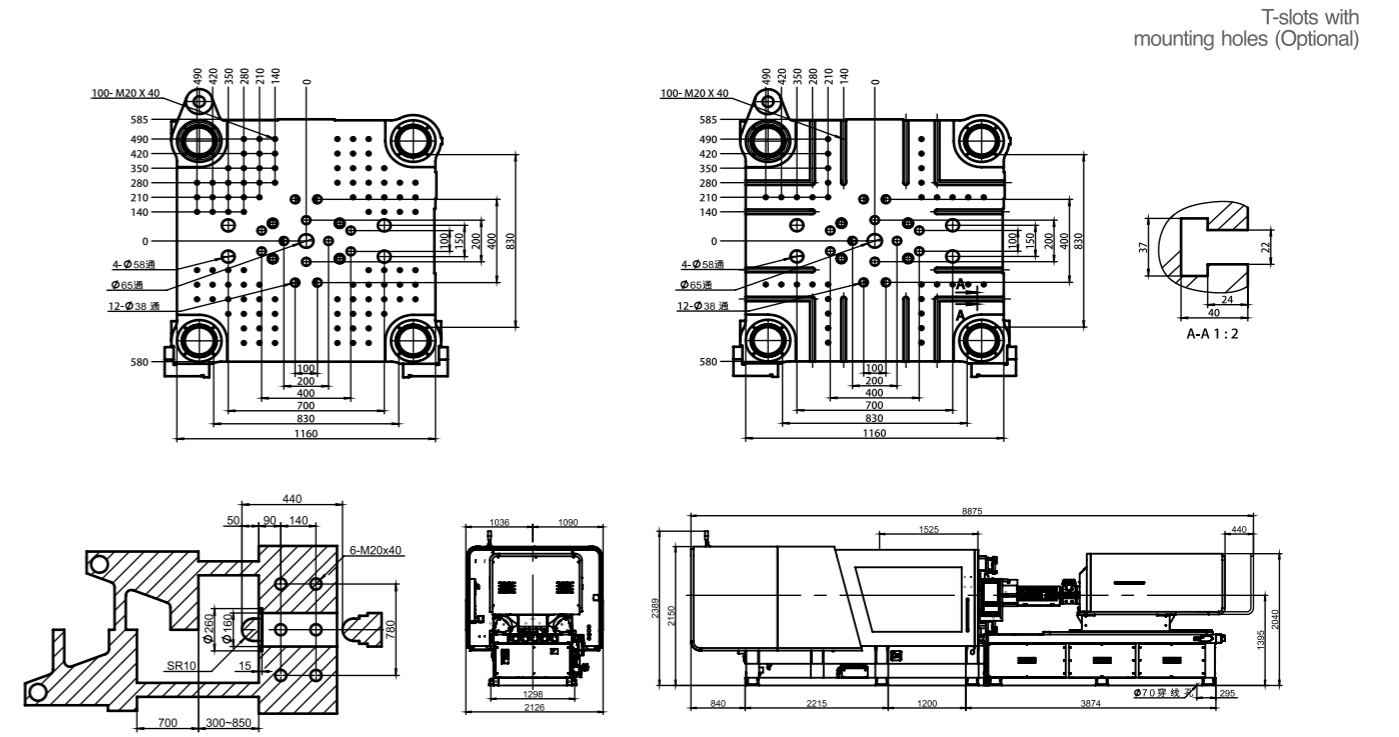

		A	B	C			
INJECTION UNIT		A	B	C	CLAMPING UNIT		
Screw Diameter	mm	60	67	75	Clamping Force	kN	3600
Screw Stroke	mm	300	330	360	Opening Force	mm	700
Swept Volume	cm ³	848	1163	1590	Min. Mould Thickness	mm	300
Shot Weight (PS)	g	780	1070	1462	Max. Mould Thickness	mm	850
Shot Weight (PS)	oz	27.6	38.8	51.6	Space Between Tie Bars (HxV)	mm	830x830
Injection Rate	cm ³ /s	565	705	883	Max. Daylight	mm	1550
Injection Speed	mm/s		200		Ejector Force	kN	111
Injection Pressure	MPa	234	188	150	Ejector Stroke	mm	200
Holding Pressure	MPa	187	150	120			
Plasticising Capacity	g/s	50	80	95	POWER PACK		
Screw Rotation Speed (max.)	rpm		235		Input Power		380V 50Hz
Barrel Heating Power	kW	30.2	33.6	39.4	Max. Power Draw	kVA	69KW/157A
Barrel Temperature Zones			3+1		Max. System Pressure	MPa	17.5
Nozzle Contact Force	kN		90		System Flow	L/min	116
					Oil Tank Capacity	L	210
OTHERS							
Machine Dimensions (LxWxH)	mm	8875x2126x2389					
Machine Weights	t	18.5					

The company keeps upgrading the products and reserves the right to change the product specifications and parameters without prior notice. The final interpretation to the above specifications and parameters belongs to the company.